

Ethernet / Fast Ethernet Bridge Module with simplex fiber (WDM)

Description

The bridge enables connection of copper and fiber segments to Ethernet and Fast Ethernet whilst at the same time altering the speed. For higher port densities there is a twin bridge available which achieves a higher port density in the distribution equipment by integrating two bridges per card.

This special simplex fiber version offers the transmission over one simplex single mode fiber. By using two different wavelengths it is possible to transmit and receive over the same fiber core. These WDM bridges should be used always in a pair.

These single mode designs are used in particular for Fiber To The Home (FTTH) projects. The end user can obtain internet services, video on demand and VoIP applications using the familiar 10/100Base-TX copper connection.

An additional operation mode offers the possibility of a symmetric bandwidth limitation. With this service provider can offer their customers individual data rates easily. The provided bandwidth can be configured in small steps to the customer requirements.

The configuration of the features can be done by the network management or the integrated configuration switches.

Construction

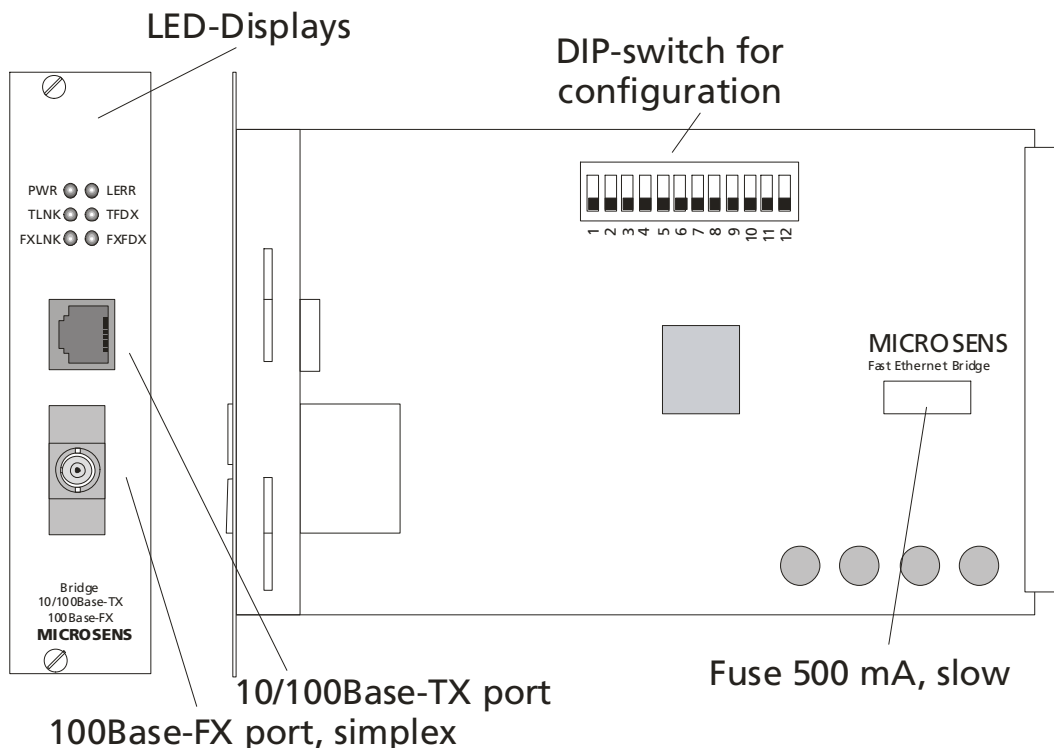

Technical Specifications

Type	Fast Ethernet Bridge For the coupling of Ethernet and Fast Ethernet segments with simplex fiber interface for the installation in the MICROSENS modular chassis	
Fiber type	single mode 9/125µm simplex	
Optical Budget	MS416162Mx	10 dB (min. at 1310 nm)
	MS416162Mx-L2	25 dB (min. at 1310 nm)
Max. distance	Full duplex: min. 20 km (MS416162Mx)* min. 30 km (MS416162Mx-L2)* Half duplex: 412 m	
Cable type	Shielded Twisted Pair cable, 100 Ohm, Category 5	
Data rate	10 or 100 Mbps	
Max. distance	100 m	
Configuration	Manually by DIP switches or by management	
LED displays	<i>PWR</i>	Module active
	<i>LNK1</i>	Twisted Pair connection correct
	<i>FD1</i>	Twisted Pair connection full duplex
	<i>LNK2</i>	Fiber connection correct
	<i>FD2</i>	Fiber connection full duplex
	<i>ALARM</i>	Link Error, no fiber connection
Power supply	12 V DC / max. 500 mA via backplane	
Operating temp.	0°C to 55°C	
Storage temp.	-20°C to 80°C	
Rel. humidity	5% to 80% non condensing	
Dimensions	3 HU x 6 DU (128 x 31 mm)	
Management	optional SNMP-/web based management with management module MS416020-B	

*The mentioned distances are recommendations, which are guaranteed during the duration of life. The distances are depending on the condition of the transmission line and can vary depending on the quality of the used fibers, connectors and other parameters. Decisive are the listed transmitter and receiver figures. Longer distances than above mentioned can be reached easily.

Operation

The module is designed for the mounting into a MICROSENS modular chassis. It can be combined with all other converter modules of the same series.

The power supply is done by a central power supply unit via the backplane of the chassis. Together with the power supply it is possible to insert up to 12 modules into the 3 U chassis. Optional it is possible to insert a second redundant power supply. In this case it is possible to use up to 10 converter modules.

Beside the 3 U chassis there is an additional 1 U chassis (horizontal slots) available. This chassis has an integrated power supply (MS416006), which can be also redundant (MS416007).

Furthermore there are in addition to the 19" racks, desktop chassis for one (MS417001) or two (MS417041) modules available. With the wall bracket (MS417001-WH) it is possible to mount the desktop chassis on the wall.

Management

The module can be configured and monitored by the central management agent. There are two different modes possible:

DIP-10 off Monitoring of the actual configuration and operation states, configuration through the NMS is not possible.

DIP-10 on Monitoring with Network management (SNMP- and web based), configuration by web management, terminal or telnet connection.

The SNMP and web based management features of the system are provided by the management master module (MS416020-B). When choosing the management features it is necessary that the chassis (e.g. MS416001M) and the power supply (MS416004M) are also supporting the management.

Visualising - and configuration-example with an SNMP management platform:

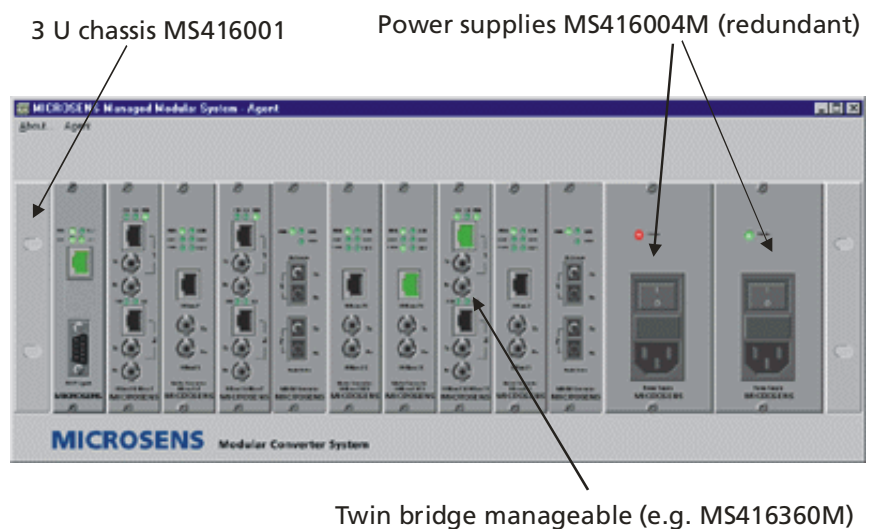

To access the data of the modules via SNMP it is necessary to integrate the structure of the MIB into the existing network management. The MICROSENENS MIB file can be downloaded from the web based management of module. The MIB file is in ASCII format.

The configuration of the network management is protected by a password. The following values are default from the factory.

	Console: Read only	Console: Admin	WEB: Configuration
Username	user	Admin	
Password	microsens	Microsens	microsens

The password for the web based configuration is the same as the administrator password of the console and can be changed together with it.

Configuration

The configuration of the ports is done manually by either the management (DIP-switch 10: on) or alternative by the DIP-switches (DIP-switch 10: off). As factory default the configuration by management is activated, to allow an immediate access to the configuration.

DIP-switch	Function (ON/OFF)
1	ALM for fiber port
2	Link Through from TP port to fiber port
3	Link Through from fiber port to TP port
4	ON: Full duplex for fiber OFF: Half duplex for fiber
5	ON: Autonegotiation for TP OFF: 100Mbps, full duplex for TP
6	Flow Control
7 – 9	Bandwidth limitation
10	ON: Conf. by Management OFF: Conf. by DIP-switches
11	Reserved
12	Reserved

The factory default settings are:

DIP-switch	Function (ON/OFF)
1	Off
2	Off
3	Off
4	ON: Full duplex for fiber
5	ON: Autonegotiation for TP (10/100Base-TX)
6	Off

7 – 9	Off
10	ON: Configuration by Management
11	Off
12	Off

Additional the bandwidth of the user data can be limited symmetric. By the software management it is possible to limit the bandwidth in steps of 32 kbps or by the DIP-switches in the following steps:

DIP-switch			Max. data rate between the ports (each direction)
7	8	9	
0	0	0	100 Mbps (100Base-TX), no limitation
0	0	1	75 Mbps
0	1	0	50 Mbps
0	1	1	34 Mbps (E3)
1	0	0	20 Mbps
1	0	1	10 Mbps (10Base-T)
1	1	0	8 Mbps
1	1	1	2 Mbps (E1)

0 = Switch OFF, 1 = Switch ON

Link Trough / ALM

The link status of each segment is forwarded, that means a missing link on the input side also the link signal of the corresponding output side is switched off physically.

Attention: If activated by the DIP-switches there is no link signal generated by the bridge in idle state. This is no malfunction!

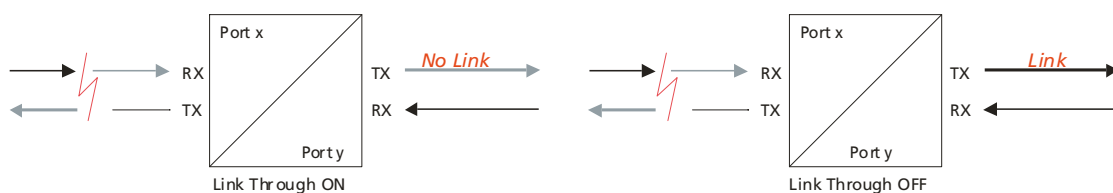

If ALM (Advanced Link Monitoring) is activated the same fiber port is not sending a link signal if he does not receive a link signal (Link Down). This ensures that both directions of the fiber line, TX and RX are having the same link status.



Safety Notes

WARNING: Infrared radiation as used for data transmission within the fiber optic, although invisible to the human eye, can nevertheless cause damage.

To avoid damage to the eyes:

- *never look straight into the output of fiber optic components – danger of blinding!*
- *cover all unused optical connections with caps.*
- *commission the transmission link only after completing all connections.*

The active laser components used with this product comply with the provisions of **Laser Class 1**.

Order Information

Art.-Nr.	Description	Connectors
MS416162MA2	Bridge Module, 10/100Base-TX/100Base-FX single mode SC simplex, manageable TX: 1310 nm, RX: 1550 nm; 20 km	1 x RJ-45 10/100TX 1 x SC 100Base-FX
MS416162MB2	Bridge Module, 10/100Base-TX/100Base-FX single mode SC simplex, manageable TX: 1550 nm, RX: 1310 nm; 20 km	1 x RJ-45 10/100TX 1 x SC 100Base-FX
MS416162MA2-L2	Bridge Module, 10/100Base-TX/100Base-FX single mode SC simplex, manageable TX: 1310 nm, RX: 1550 nm; 30 km	1 x RJ-45 10/100TX 1 x SC 100Base-FX
MS416162MB2-L2	Bridge Module, 10/100Base-TX/100Base-FX single mode SC simplex, manageable TX: 1550 nm, RX: 1310 nm; 30 km	1 x RJ-45 10/100TX 1 x SC 100Base-FX

MICROSENS reserves the right to make any changes without further notice to any product to improve reliability, function or design. MICROSENS does not assume any liability arising out of the application or use of any product. 3206/He